

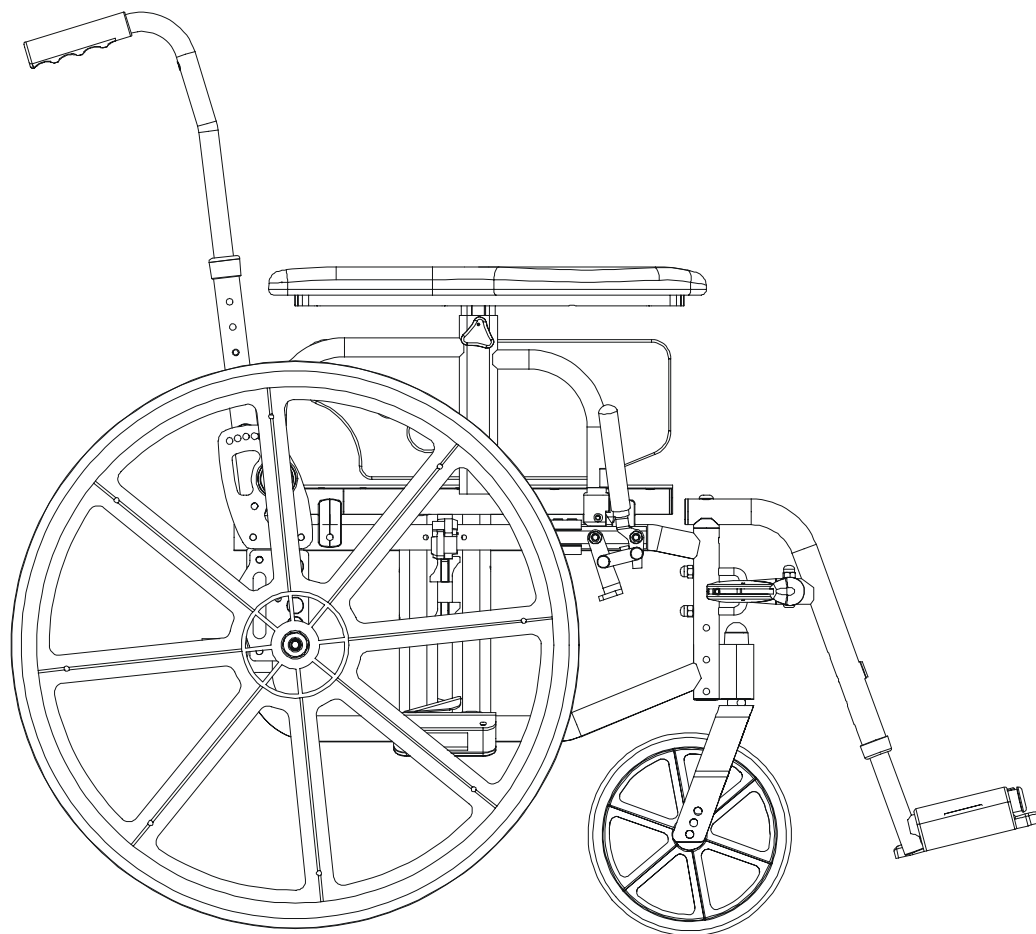

Owner's Operations Manual



StellatoOperating Instructions

NOTE: Check all parts for shipping damages before using.
In case of damage, do NOT use the equipment.
Contact the Equipment Supplier for further instructions.

WARNING
DO NOT install this equipment without first reading and understanding this instruction booklet. If you are unable to understand these instructions, contact a healthcare professional, dealer or technical personnel before attempting to install this equipment - otherwise, injury or damage may occur.

NOTICE
Information contained within this document is subject to change without notice.

STELLATO LABELS

WEIGHT CAPACITY
250 LBS. (114 kgs)
REFER TO OWNER'S MANUAL

WARNING
DO NOT OPERATE WITHOUT
THE ANTI-TIP TUBES
INSTALLE

TABLE OF CONTENTS

Labels.....	2
Specifications.....	4
General Guidelines.....	5
Safety Inspection.....	8
Front Rigging.....	9
Arms.....	11
Seat & Back.....	13
Rear Wheels.....	15
Front Casters.....	17
Anti-tippers & Wheel Locks.....	19
Warranty.....	22

STELLATO SPECIFICATIONS

	STELLATO
Overall Width:	Max. 28", Min. 22"
Overall Depth: (with front rigging)	Max. 47" (rear wheel – rear position)
Seat Width:	14" – 20"
Seat Depth:	15" – 20"
Seat-to-Floor:	
Small frame	13.25" – 18 "
Large frame	15.5" – 19 "
Back Style:	Slip on back upholstery Adjustable angle 10 degree bend w/Push Handle
Back Height:	19" – 22" Low, 22" – 25" High
Arm Styles:	Full length adjustable height flip back (gel or foam pad) Full length height adjustable flip back (vinyl pad)
Front Rigging:	Swingaway Footrests and Elevating Legrests
Rear Axle:	Permanent and Quick-Release
Rear Wheels:	20", 22" or 24" Composite Urethane
Handrims:	Stainless Steel or Plastic Coated
Wheel Locks:	Push or Pull to Lock
Caster Size:	4", 5" and 7"x1" and 8" x 1.25" Urethane
Upholstery:	Black Nylon
Frame Colours:	Black or Silver
Weight:	31 lbs.
Shipping Weight:	42 lbs. (approximate)

GENERAL GUIDELINES

STABILITY

WARNING

The seat depth, back height/angle, seat angle, size/position of the front casters, size/position of the rear wheels, anti-tipper model, as well as the user condition directly relate to the stability of the wheelchair. Any change to one (1) or any combination of the ten (10) may cause the wheelchair to decrease in stability. These adjustments **MUST** be performed by a qualified technician.

The various seat-to-floor heights require specific settings depending on rear wheel size, rear wheel position, front caster size/position and desired seat-to-floor angle. These adjustments **MUST** be performed by a qualified technician.

ANTI-TIPPERS

WARNING

Seat-to-floor angle of 0 or 3 degrees: if so equipped, anti-tippers **MUST** be attached at all times. In as much as the anti-tippers are an option for 0 or 3 degrees on this wheelchair (you may order with or without the anti-tippers), Future Mobility Healthcare Inc. strongly recommends ordering the anti-tippers as a safeguard for the wheelchair user.

OPERATING INFORMATION

WARNING

Unless otherwise noted, all service and adjustment should be performed while the wheelchair is unoccupied.

To determine and establish your particular safety limits, practice bending, reaching and transferring activities in several combinations in the presence of a qualified healthcare professional **BEFORE** attempting active use of the wheelchair.

Always verify that hand grips on the rear cane are secure **PRIOR** to use when an attendant is used to propel or lift the chair. Check for any signs of looseness or deterioration and if found, contact a qualified technician. **DO NOT** attempt to move the wheelchair by using the hand grips if they are found to be unsecure or have deteriorated.

- **DO NOT** sit or transfer into the wheelchair unless it is fully open and the seat frame rails are fully seated into the side frame H-blocks.
- **DO NOT TRAVERSE, CLIMB or GO DOWN** ramps or slopes greater than 9 degrees
- **DO NOT** attempt to move up or down an incline with a water, ice or oil film
- **DO NOT** operate on roads, streets or highways

- **DO NOT** attempt to ride over curbs or obstacles. Doing so may cause your wheelchair to tip over and cause bodily harm to you or damage to the wheelchair.
- **DO NOT** attempt to reach objects if you have to move forward in the seat.
- **DO NOT** attempt to reach objects if you have to pick them up from the floor by reaching down between your knees.
- **DO NOT** lean over the top of the back upholstery. This will change your center of gravity and may cause you to tip over.
- **DO NOT** shift your weight or sitting position toward direction you are reaching as the wheelchair may tip over.
- **WHEEL LOCKS ARE NOT BRAKES. DO NOT** attempt to stop a moving wheelchair with wheel locks.
- **DO NOT** tip the wheelchair without assistance.
- **DO NOT** use an escalator to move a wheelchair between floors. Serious bodily injury may occur.
- Before attempting to transfer in and out of the wheelchair, every precaution should be taken to reduce the gap distance. Turn both casters parallel to the object you are transferring onto. When transferring to and from the wheelchair, **ALWAYS ENGAGE BOTH WHEEL LOCKS.**
- **DO NOT** use parts, accessories or adapters other than those authorized by Future Mobility Healthcare Inc. Otherwise, the warranty is void.
- **DO NOT** attempt to lift the wheelchair by any removable (detachable) part. Lifting by means of any removable (detachable) parts of a wheelchair may result in injury to the user and/or assistant or damage to the wheelchair.
- **DO NOT** stand on the frame of the wheelchair.
- **DO NOT** use the footplate as a platform. When getting in or out of the wheelchair, make sure that the footplates are in the upward position.

WEIGHT TRAINING

WARNING

Future Mobility Healthcare Inc. **DOES NOT** recommend the use of its wheelchairs as a weight training apparatus. Future Mobility Healthcare Inc. wheelchairs have **NOT** been designed or tested as a seat for any kind of weight training. If occupant uses said wheelchair as a weight training apparatus, Future Mobility Healthcare Inc. shall **NOT** be liable for bodily injury or damage to the wheelchair and the warranty is void.

WEIGHT LIMITATION

WARNING

The Stellato wheelchair has a weight limitation of 250 lbs. (114kg).

UNFOLDING AND FOLDING THE WHEELCHAIR

WARNING

Keep hands and fingers clear of moving parts to avoid injury. **DO NOT** sit or transfer into the wheelchair unless it is fully open and the seat frame rails are fully seated into the side frame H-blocks.

Unfolding:

1. Open the wheelchair by grasping the armrest of the wheelchair closest to you
2. Tilt the wheelchair towards you (raising the opposite wheel and caster off the ground/floor).
3. Push downward on the TOP of the seat rail closest to you where the seat upholstery is attached until the wheelchair is fully open and locked into H-blocks.
4. Engage both wheel locks, open the footrest/legrest for clearance and transfer into the wheelchair.

Folding “Hammock or Sling Seat” Models:

1. Swing footrest/legrest in locked position to the front of the wheelchair.
2. Pivot footplates upward to vertical position.
3. With both hands, grasp the middle of the seat upholstery at the front and back edge and lift up.
4. Continue to close the wheelchair by grasping the armrest furthest from you and pulling the armrest towards you.

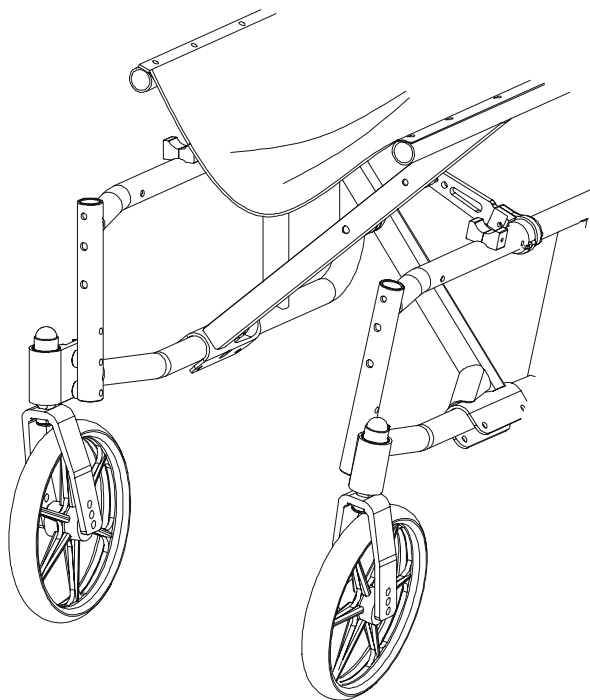

SAFETY INSPECTION CHECKLIST

Initial adjustments should be made to suit your personal body structure needs and preference. Thereafter follow these maintenance procedures:

Item	Initially	Weekly	Monthly	Periodically
GENERAL <ul style="list-style-type: none"> • Wheelchair rolls straight (no excessive drag or pull to one side) 	X		X	
FRAME AND CROSSBRACES <ul style="list-style-type: none"> • Inspect for loose or missing hardware • Inspect for bent frame or crossbraces 	X X			X X
WHEEL LOCKS <ul style="list-style-type: none"> • Do not interfere with tires when rolling • Pivot points free of wear and looseness • Wheel locks easy to engage • Wheel locks prevent chair from moving when engaged 	X X X X	X	X X	X
SEAT AND BACK <ul style="list-style-type: none"> • Inspect for rips or sagging • Inspect for loose or broken hardware • Inspect cane and hand grips for wear/looseness 	X X X		X X	X
TIRES <ul style="list-style-type: none"> • Inspect for flat spots, cracks and wear Caution: as with any vehicle, the wheels and tires should be checked periodically for cracks and wear and should be replaced.	X	X		X
REAR WHEELS <ul style="list-style-type: none"> • If equipped, quick-release axles lock properly • No excessive side movement or binding when lifted and spun • Inspect for cracked, bent or broken spokes 	X X X	X X		X
HANDRIMS <ul style="list-style-type: none"> • Inspect for signs of rough edges or peeling 	X			X
FRONT CASTERS/FORKS <ul style="list-style-type: none"> • Inspect axle assembly for proper tension by spinning caster; caster should come to a gradual stop • Adjust bearing system if wheel wobbles or binds to a stop. Ensure wheel bearings are clean and free of moisture. • Check headtube locknuts for tightness • Inspect casters for cracks and wear • Inspect for cracked, bent or broken spokes 	X X X X X	X X	X X	X X
CLEANING <ul style="list-style-type: none"> • Clean upholstery and armrests 	X			X

TROUBLESHOOTING

Chair Veers Right/Left	Chair 3 Wheels	Sluggish Turn or Performance	Caster Flutter	Squeaks and Rattles	Looseness in Chair	Solutions
X	X	X	X			Check tires for correct and equal pressure.
		X	X	X	X	Check for loose nuts and bolts
X	X		X			Check caster headtube angle.
X	X					Check that rear wheels are equally spaced away from seat frame.

FRONT RIGGINGS

WARNING

After **ANY** adjustments, repair or service and **BEFORE** use, make sure all attaching hardware is tightened securely – otherwise injury or damage may occur.

INSTALLING/REMOVING THE FRONT RIGGINGS

Installing:

1. Turn the front rigging assembly to the side (open front rigging is perpendicular to wheelchair)
2. Install the hinge plates on the front rigging assembly onto the hinge pins on the wheelchair frame.
3. Push the front rigging assembly towards the inside of the wheelchair until it locks into place.
4. Repeat this procedure for the other front rigging assembly.
5. To release the front rigging, pull the front rigging release lever outward, rotate front rigging outward.

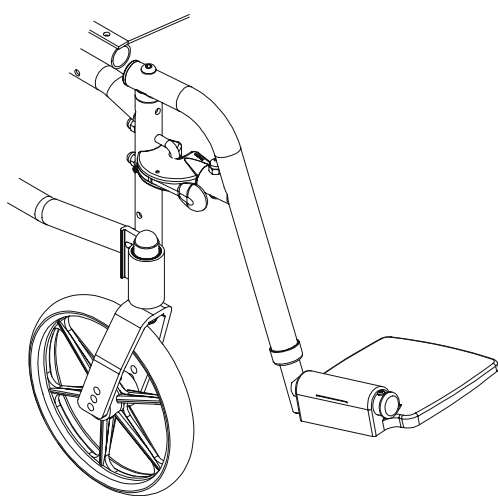

(Upgraded)

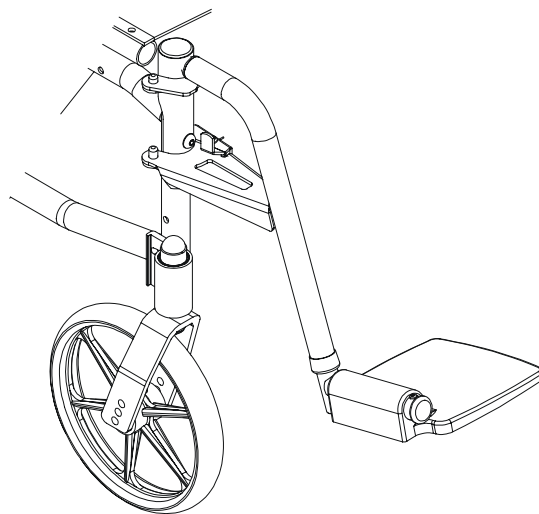

(Pinstyle)

Removing:

1. Pull the front rigging release lever outward.
2. Rotate swingaway front rigging assembly outward.
3. Lift the swingaway front rigging assembly off the hinge pins.

FOOTPLATE HEIGHT ADJUSTMENT

Note: This procedure applies to the swingaway front riggings and swingaway elevating legrest.

1. Remove the front rigging assembly. Refer to INSTALLING/REMOVING THE FRONT RIGGING in this section of the manual.
2. Remove footrest bracket bolt. Slide footrest extension tube up or down to desired height.
3. Re-tighten bolt.

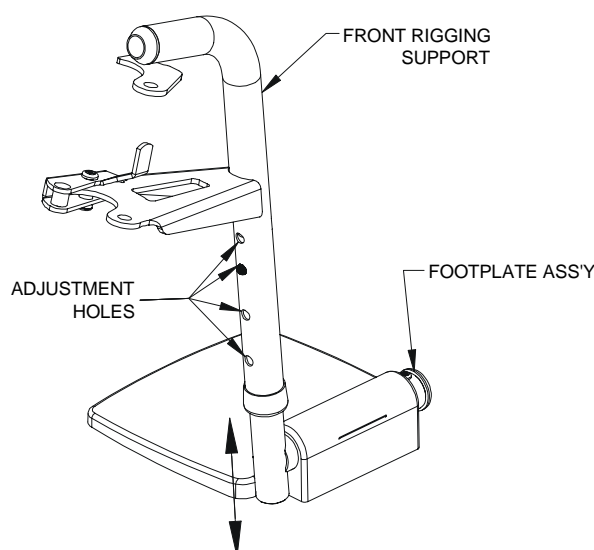
**Bolt-on-place Footplate Height Adjustable****ELEVATING LEGREST ASSEMBLY****WARNING**

Ensure hands and fingers are clear of elevating legrest mechanism **BEFORE** pushing release lever to lower the elevating legrest. Otherwise injury may occur due to pinch points. The wheelchair user's leg **MUST** be supported by an assistant **BEFORE** attempting to lower legrest.

Instructions: Installing the Elevating Legrest

1. Insert the legrest adjustable hanger into the opening of the seat frame tube.
2. Position the elevating legrest swing-away section onto the hanger by dropping the pivot plug into the open end of the hanger vertical tube.
3. Swing inwards until the latch engages and locks into the "U – Bolt".
4. Adjust footplate and calf pad position to fit user's leg length.

ELEVATING LEGREST OPERATION

Instructions: Raising/Lowering the Elevating Legrest

1. To adjust the angle of the elevating legrest, turn the handle knob counter-clockwise to disengage from the index rod.
2. Lift the legrest to the desired angle.
3. Re-tighten the handle knob such that the legrest arm remains firmly in position.
4. Swing inwards until the latch engages and locks into the "U – Bolt".

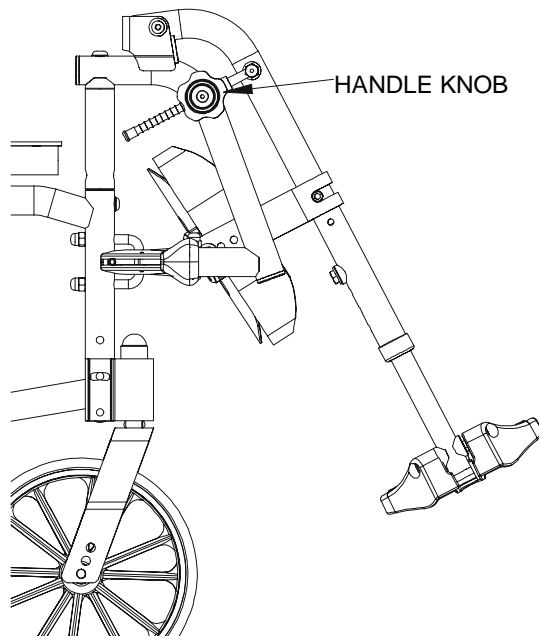

Elevating Legrest - Mounted

ARMS

WARNING

After **ANY** adjustments, repair or service and **BEFORE** use, make sure all attaching hardware is tightened securely – otherwise injury or damage may occur.

Flip-up Arm Rests

Arm Height Adjustment; Height Adjustable Arm Rest

1. Loosen knob.
2. Lift armrest until desired position is acquired (ranges from 9 ½" – 14" in ½" increments).
3. Re-tighten knob.

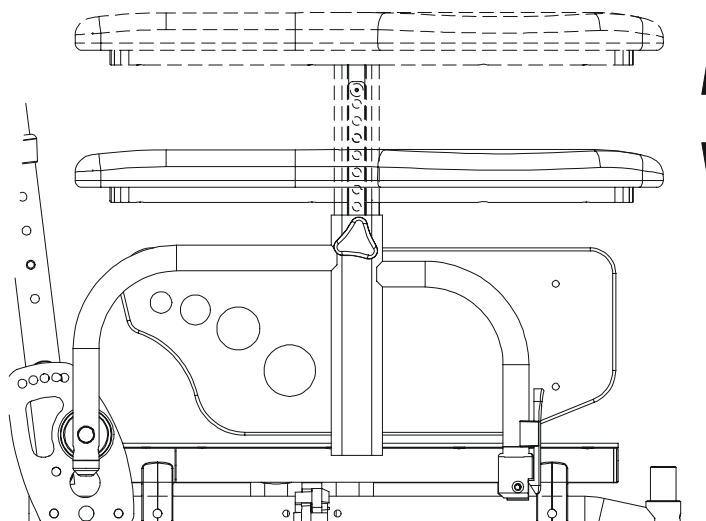

Height Adjustment

Flip-up Arm Rests

Engaging and Disengaging Flip-up style armrest

1. To engage, push armrest into arm socket until release lever is engaged into slot.
2. For flip-up, push and hold release lever, while lifting armrest from arm socket.

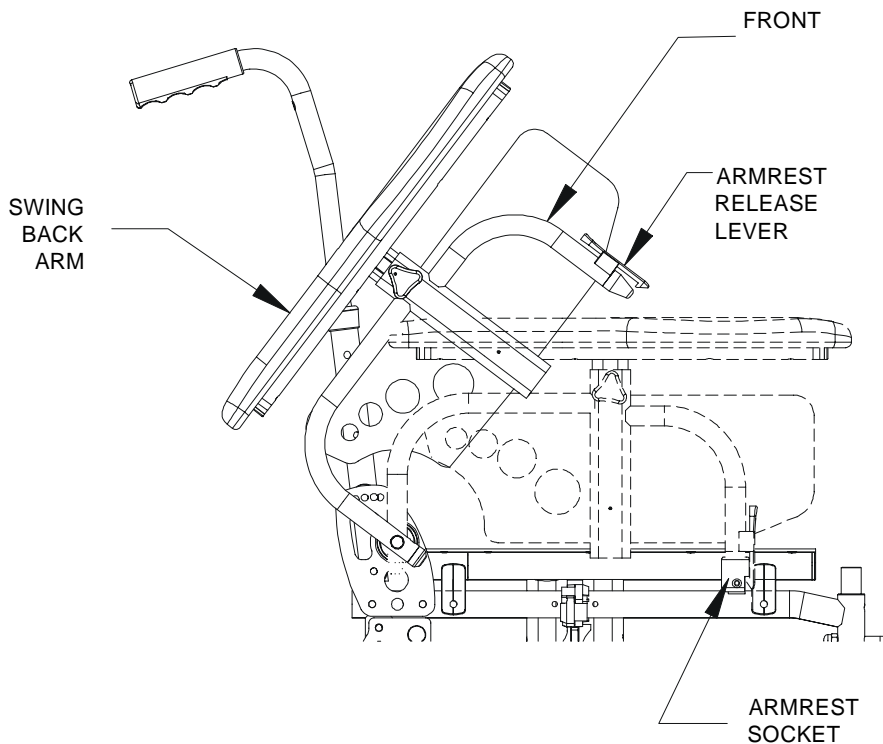

Engaging/Disengaging Flip-up Arm Rest

SEAT AND BACK

WARNING

After **ANY** adjustments, repair or service and **BEFORE** use, make sure all attaching hardware is tightened securely – otherwise injury or damage may occur.

REPLACING THE SEAT UPHOLSTERY

1. Remove the front universal plugs that retain the existing insert rod to the wheelchair seat rail.
2. Remove the existing seat upholstery from the seat rail.
3. Install **NEW** seat upholstery by reversing steps 1 and 2.

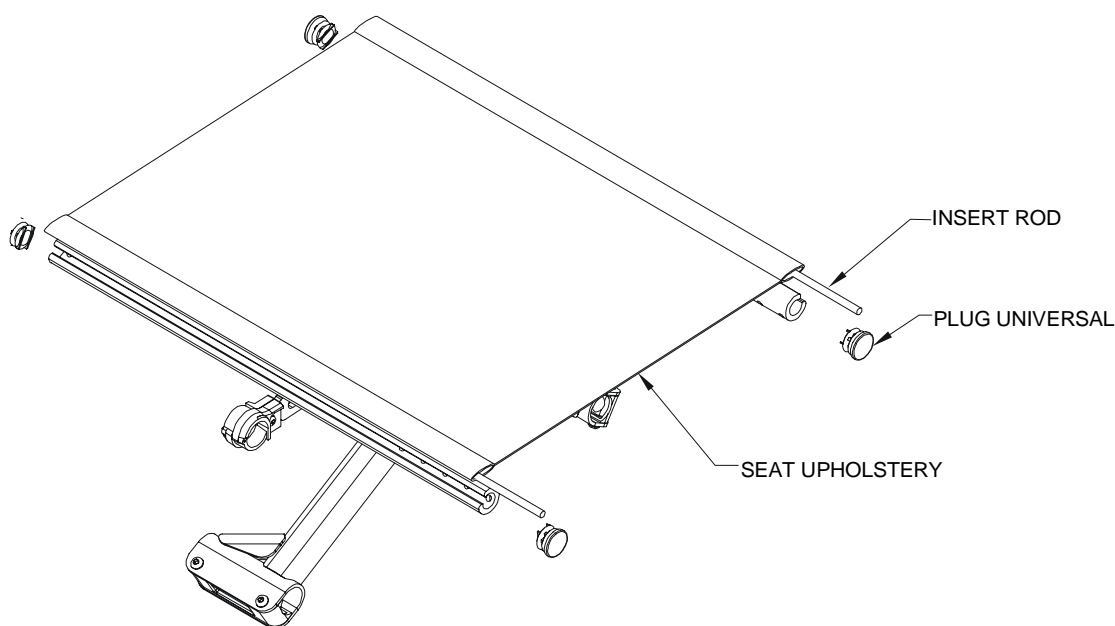

Seat Upholstery

REPLACING THE BACK UPHOLSTERY

Slip on Back Upholstery

1. Remove the two (2) mounting screws and washers that secure the existing back upholstery to the back canes.
2. Pull the loose back cane out of the existing back upholstery.
3. Pull the existing back upholstery up and over the mounted back cane.
4. Install the NEW back upholstery over the mounted back cane.
5. Slide the loose back cane through the NEW back upholstery.
6. Secure the back cane to the wheelchair frame with the two (2) allen screws and locknuts.
7. Secure the NEW back upholstery to the back canes with the existing mounting screws and washers.

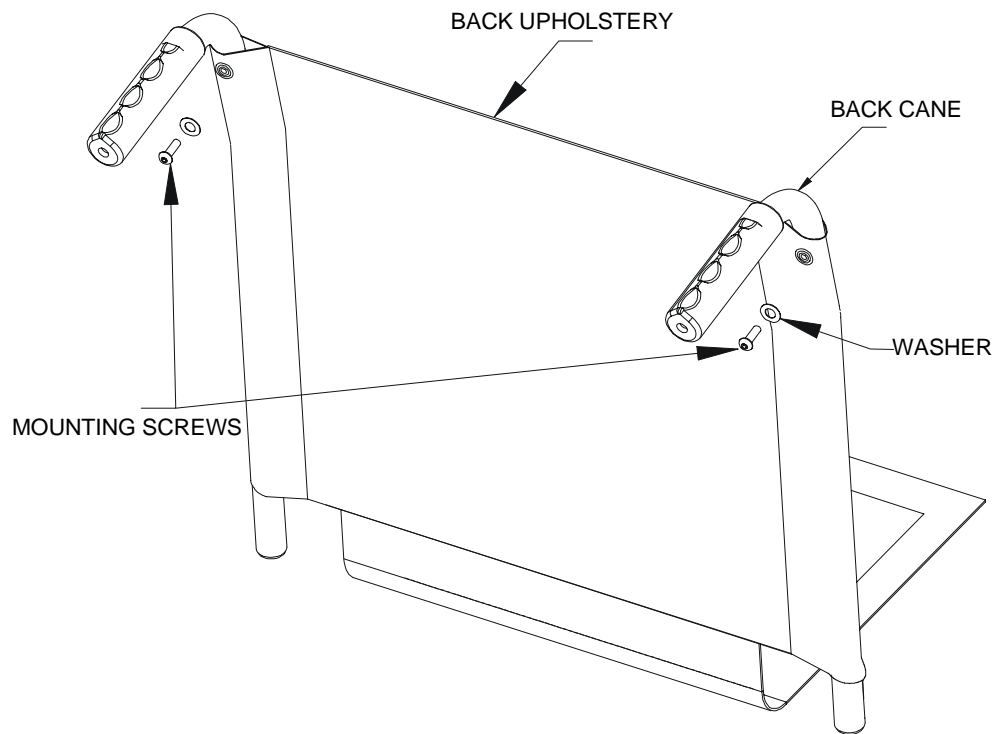

Back Slide-on Upholstery

REAR WHEELS

WARNING

After **ANY** adjustments, repair or service and **BEFORE** use, make sure all attaching hardware is tightened securely – otherwise injury or damage may occur.

REMOVING/INSTALLING THE REAR WHEELS

WARNING

If changing the size of the rear wheel or a change in the seat-to-floor height is desired, this procedure **MUST** be performed by a qualified technician.

QUICK-RELEASE AXLES

1. Push in the detent pin of the quick-release axle (with wheel) and pull the axle out through the opening in the center of the rear wheel and axle spacer.
2. Push in the detent pin of the quick-release axle again and pull the axle out of the rear wheel
3. Repeats steps 1 & 2 for the opposite rear wheel.
4. To reinstall the rear wheel onto the wheelchair, reverse steps 1 to 3.

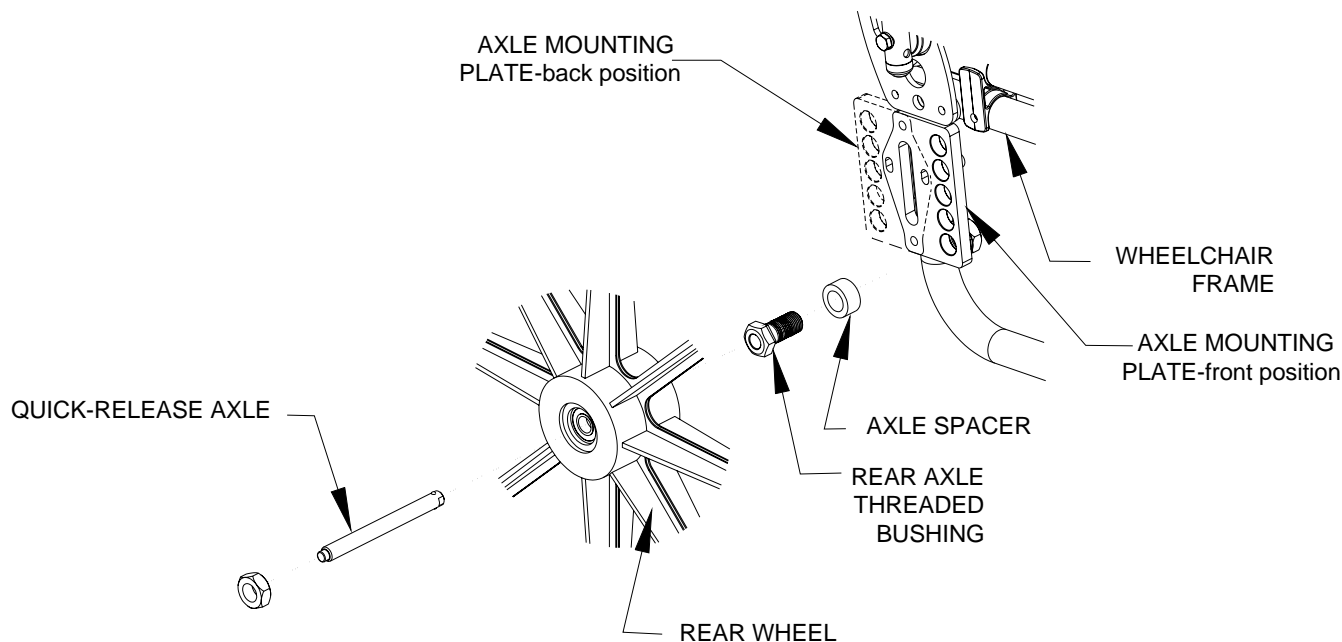

Removing/Installing the Rear Wheels

WARNING

Make sure the detent pin and locking pins of the quick-release axle are fully released **BEFORE** operating the wheelchair.

The locking pins **MUST** be protruding past the inside of the rear wheel axle bushing for a positive lock.

Keep locking pins clean.

Future Mobility Healthcare Inc. recommends inserting quick-release axles with the detent pin to the inside of the wheelchair to prevent accidental release during contact activities.

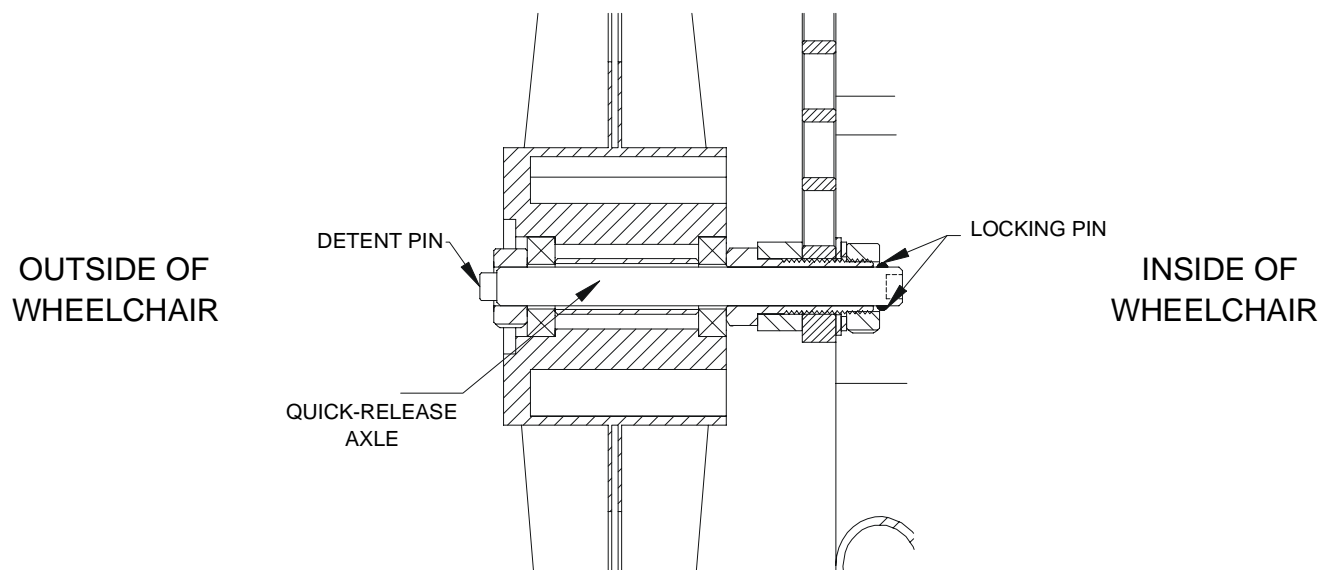

Detail – Locking Pin and Detent Pin

FRONT CASTERS

WARNING

After **ANY** adjustments, repair or service and **BEFORE** use, make sure all attaching hardware is tightened securely – otherwise injury or damage may occur.

INSTALLING/REPLACING FRONT CASTERS AND FORKS

Note: This procedure can be performed if replacing the exact same size front caster.

1. Remove dust cover.
2. Remove the locknut that secures the fork to the caster headtube.
3. Drop the front caster and fork out of the caster headtube.
4. Slide in the new six/eight inch front caster and fork.
5. Reassemble by reversing STEPS 1 to 3.
6. Repeat STEPS 1 to 5 for the opposite front caster.
7. To properly tighten caster journal system and guard against flutter, perform the following check:
 - a. Tip back of wheelchair to floor
 - b. Pivot both forks and casters to top of their arc simultaneously.
 - c. Let casters drop to bottom of arc (wheels should swing once to one-side, then immediately rest in a straight downward position).
 - d. Adjust locknuts according to freedom of caster swing.
8. Test wheelchair for maneuverability.
9. Readjust locknuts if necessary and repeat STEPS 7 to 8 until correct.
10. Snap dust cover over the locknut and stem.

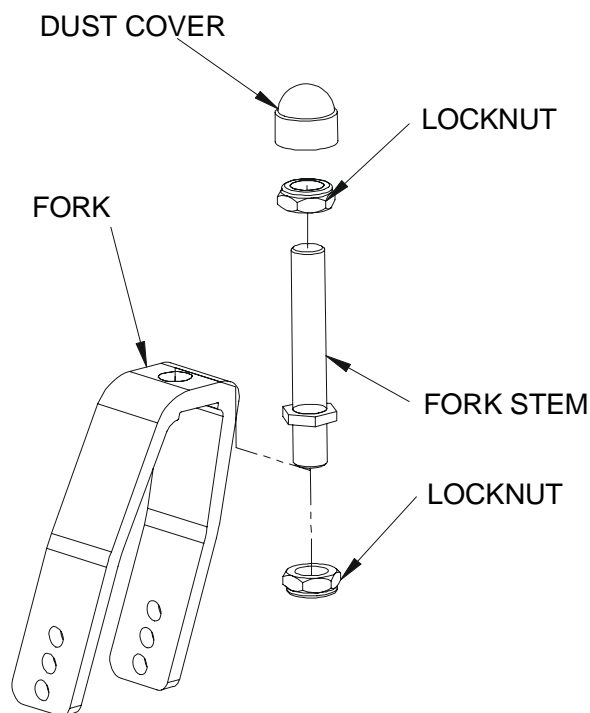

Fork Stem Assembly

ADJUSTING FRONT CASTER ANGLE

1. Remove bolt and loosen locknut.
2. Adjust cam plate for angle.
3. Reinsert bolt, tighten locknut.

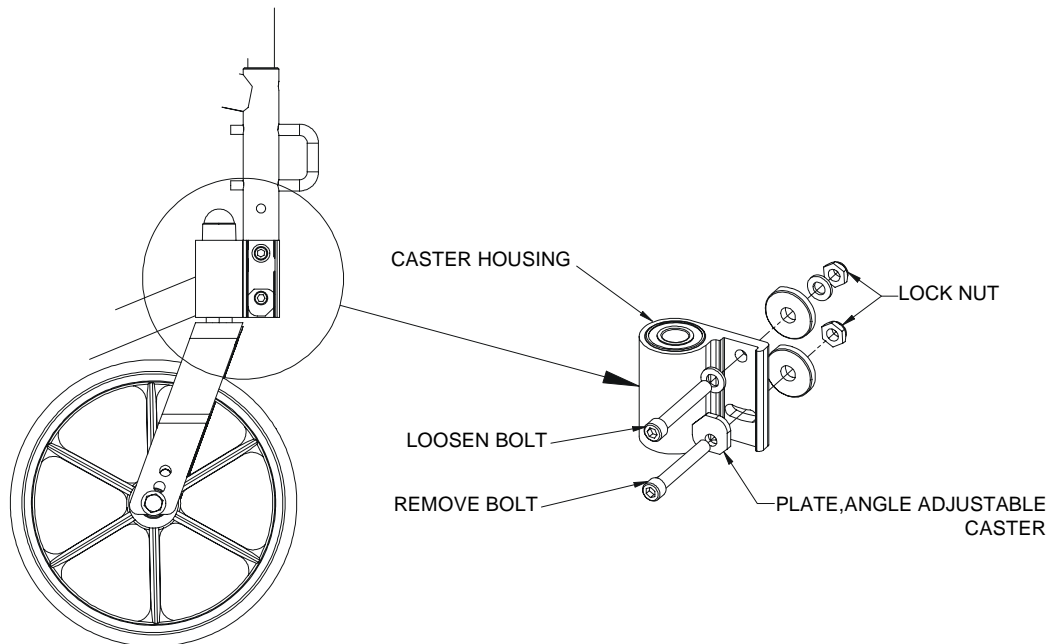

Position 1	Position 2	Position 3
0 degrees	4 degrees	7 degrees

PLATE-ANGLE ADJUSTABLE

POSITION 1 POSITION 2 POSITION 3

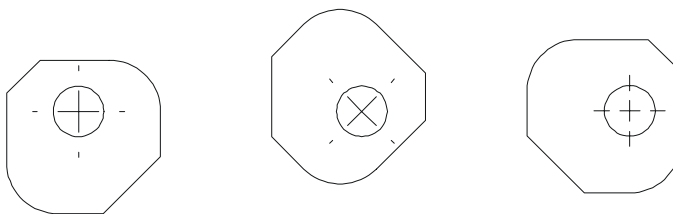

(nominal)

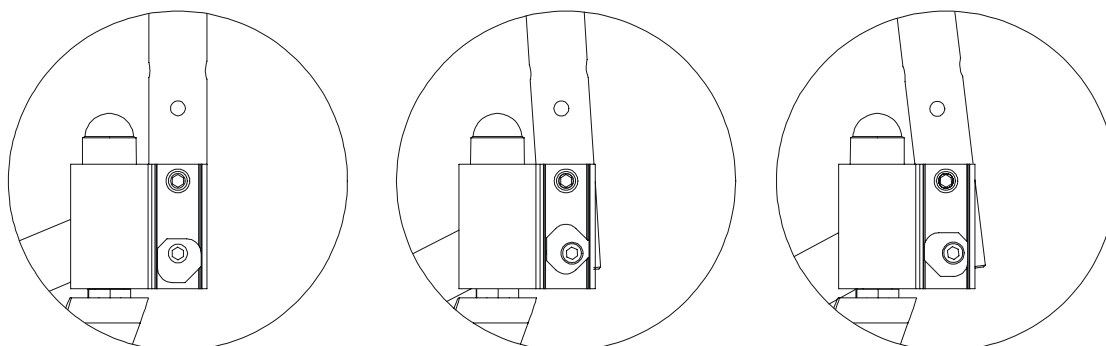

ANTI-TIPPERS/WHEEL LOCKS

WARNING

After **ANY** adjustments, repair or service and **BEFORE** use, make sure all attaching hardware is tightened securely – otherwise injury or damage may occur.

INSTALLING/ADJUSTING THE ANTI-TIPPERS

WARNING

Anti-tippers are specific to the different seat-to floor angles and/or seat-to-floor heights. Refer to the chart in this section of the manual for correct usage and adjustment. If these requirements **CANNOT** be achieved, **DO NOT** use the wheelchair. Contact a qualified technician. If changing the seat-to-floor height with or without a change to seat-to-floor angle, the correct anti-tippers **MUST** be used to maintain a 1 ½ “ to 2” ground clearance.

Seat-to-floor angle of 0 degrees to 3 degrees: if so equipped, anti-tippers **MUST** be attached at all times. In as much as the anti-tippers are an option for 0 degrees or 3 degrees on this wheelchair (you may order with or without the anti-tippers), Future Mobility Healthcare Inc. strongly recommends ordering the anti-tippers as a safeguard for the wheelchair user.

Seat-to-floor angle of 6 degrees: if changing the seat-to-floor angle to 6 degrees, anti-tippers **MUST** be ordered and installed.

Anti-tippers **MUST** be fully engaged and release buttons fully protruding out of adjustment holes.

Ensure both anti-tippers are adjusted to the same mounting hole.

INSTALLING ANTI-TIPPERS

1. Press the release buttons **IN** and insert the anti-tippers with the anti-tipper wheels pointing toward the ground/floor into the rear frame tubing until the bottom release button locks in place.
2. Measure the distance between the bottom of the anti-tipper wheels and the ground/floor.
3. If the distance between the bottom of the anti-tipper wheels and the ground/floor is not 1 ½ “ to 2”, adjust the anti-tippers. Refer to ADJUSTING THE ANTI-TIPPERS in this section of the manual.

*Note: A 1 ½ “ to 2” clearance between the bottom of the anti-tipper wheels and the ground/floor **MUST** be maintained at all times.*

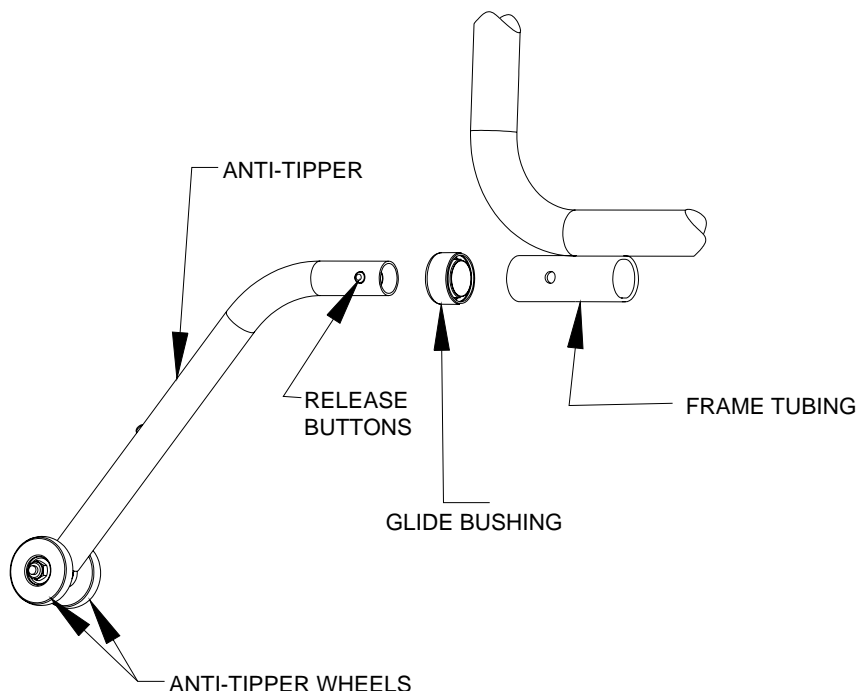

ADJUSTING THE ANTI-TIPPERS

1. Press the release buttons on the wheeled portion of the anti-tipper and slide it up or down to achieve the 1 ½ " to 2" clearance.
2. Check to make sure that the release buttons are fully engaged in adjustment holes.

NOTE: Refer to the following chart to ensure the correct anti-tipper is installed in the wheelchair. Seat-to-floor heights are approximate depending on front caster size and type.

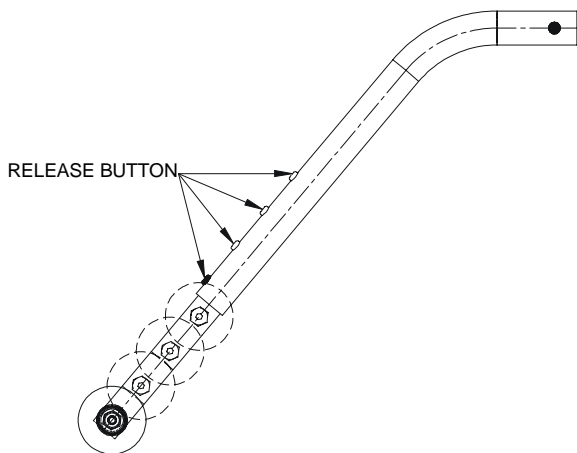

STELLATO	
Seat to Floor Height	Anti-Tippers
13.25" – 14.5"	Small Anti-tip assembly (1003816)
15" – 16.5"	Medium Anti-tip assembly (1006351)
17" – 19.0"	Large Anti-tip assembly (1003815)

USING/ADJUSTING THE DISK WHEEL LOCKS

WARNING

DO NOT attempt to stop a moving wheelchair with the wheel locks. **WHEEL LOCKS ARE NOT BRAKES** – otherwise injury or damage may occur.

1. Ensure the wheelchair is not moving before engaging the wheel locks.
2. Perform one (1) of the following:
 - a. Push-to-Lock – to engage, push the wheel lock handle forward
 - b. Pull-to-Lock – to engage, pull the wheel lock handle backward
3. Disengage the wheel locks by reversing STEP 2.

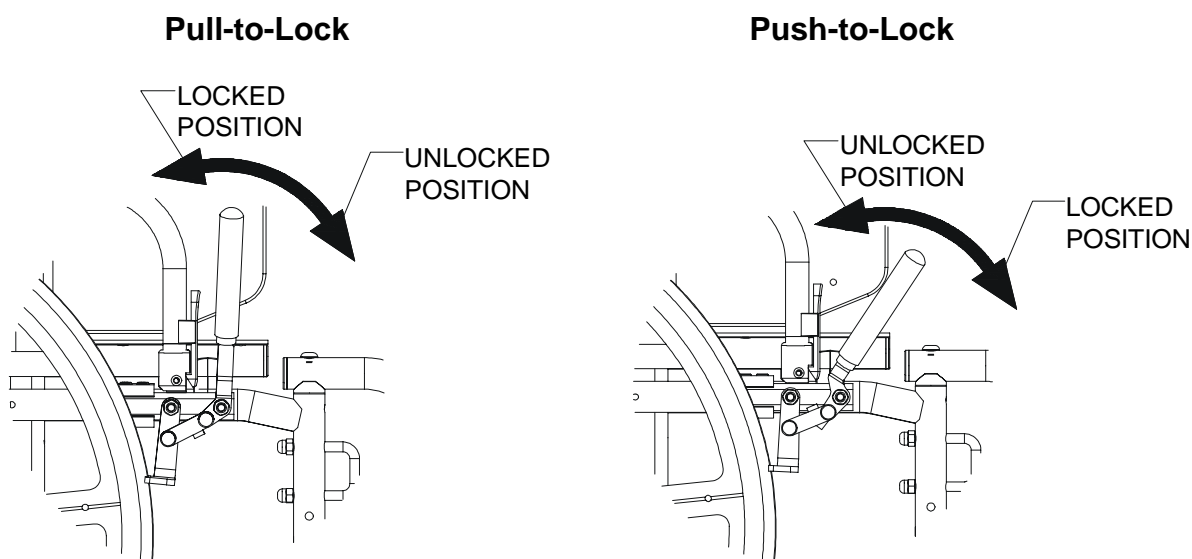

ADJUSTING THE PATIENT OPERATED WHEEL LOCKS – Refer to figure on page 22

1. Disengage the wheel locks.
2. **CLAMP-ON** Wheel Locks – loosen the two (2) socket screws that secure the wheel lock to the wheelchair frame.
3. Reposition the wheel lock so that when engaged, the wheel lock shoe embeds the tire 1/8" (3/16" for pneumatic tires) and **HOLDS** the occupied wheelchair in place when pushed.
4. Securely tighten the bolt and locknut or socket screws securing the wheel lock to the wheelchair frame.
5. Engage the wheel lock.
6. Measure the distance the wheel lock is embedded into the tire
7. Repeat STEPS 1 to 6 until the wheel lock shoe embeds the tire and **HOLDS** the occupied wheelchair in place when pushed.
8. Engage both wheel locks and ensure the occupied wheelchair is held in place when pushed.

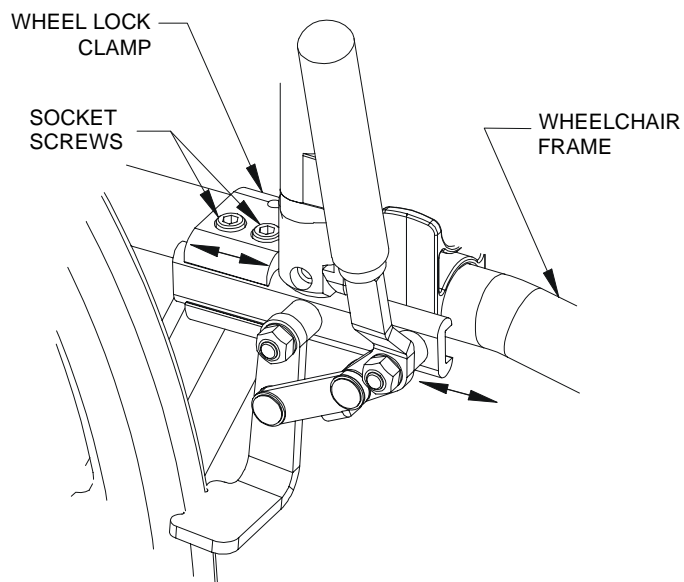

Positioning the Wheel Locks

WARRANTY

This warranty is extended only to the original purchaser/user of our products.

Future Mobility Healthcare Inc. warrants its Orion Stellato Wheelchair to be free from defects in materials and workmanship for one (1) year from the date of purchase. The frame is warranted for the lifetime of the original purchaser/user and the upholstery for 90 days, upon normal usage by original purchaser. If within this warranty period the product shall be proven to be defective, such product shall be repaired or replaced, at Future Mobility Healthcare Inc. discretion. Future Mobility Healthcare Inc. sole obligation and your exclusive remedy under this warranty shall be limited to the repair and/or replacement of the product or its parts. This warranty does not include any labour or shipping charges incurred in replacement part installation or repair of any product.

For warranty service, please contact the dealer from whom you purchased your Future Mobility Healthcare Inc. product. In the event you do not receive satisfactory warranty service, please write directly to Future Mobility Healthcare Inc. at 3223 Orlando Drive, Mississauga, Ontario, L4V 1C5. Provide the dealer's name, address, model number, date of purchase and indicate the nature of the defect.

DO NOT return products to Future Mobility Healthcare Inc. without our prior consent. The defective unit or parts must be returned for warranty inspection within thirty (30) days of the return authorization date. (Future Mobility Healthcare Inc. will issue a return authorization number). Please prepay all shipping charges; C.O.D. shipments will be refused.

LIMITATIONS and EXCLUSIONS: This warranty shall not apply to problems arising from normal wear or failure to adhere to the enclosed instructions. Products subjected to negligence, accident, improper usage, maintenance or storage; or products modified without Future Mobility Healthcare Inc. written consent including, but not limited to: modification through the use of any unauthorized parts or attachments; products damaged by reason or repairs made to any component without the specific consent of Future Mobility Healthcare Inc., or products repaired by anyone other than a Future Mobility Products dealer. Such evaluation shall be determined by Future Mobility Healthcare Inc..

The foregoing warranty is exclusive and in lieu of all other expressed warranties. It shall not extend beyond the duration of the expressed warranty provided herein and the remedy for violations of any implied warranty shall be limited to repair or replacement of the defective product pursuant to the terms contained herein. Future Mobility Healthcare Inc. shall not be liable for any consequential or incidental damages whatsoever.

This warranty shall be extended to comply with all provincial laws and requirements.

Future Mobility Healthcare Inc.
3223 Orlando Drive
Mississauga, ON L4V 1C5
905 671-1661 – 1 888 737-4011
Fax: 905 671-3377
e-mail: customersupport@future-mobility.com
www.future-mobility.com

